

Path



Raster



Both(Path and Raster)

Perspective Projection

---

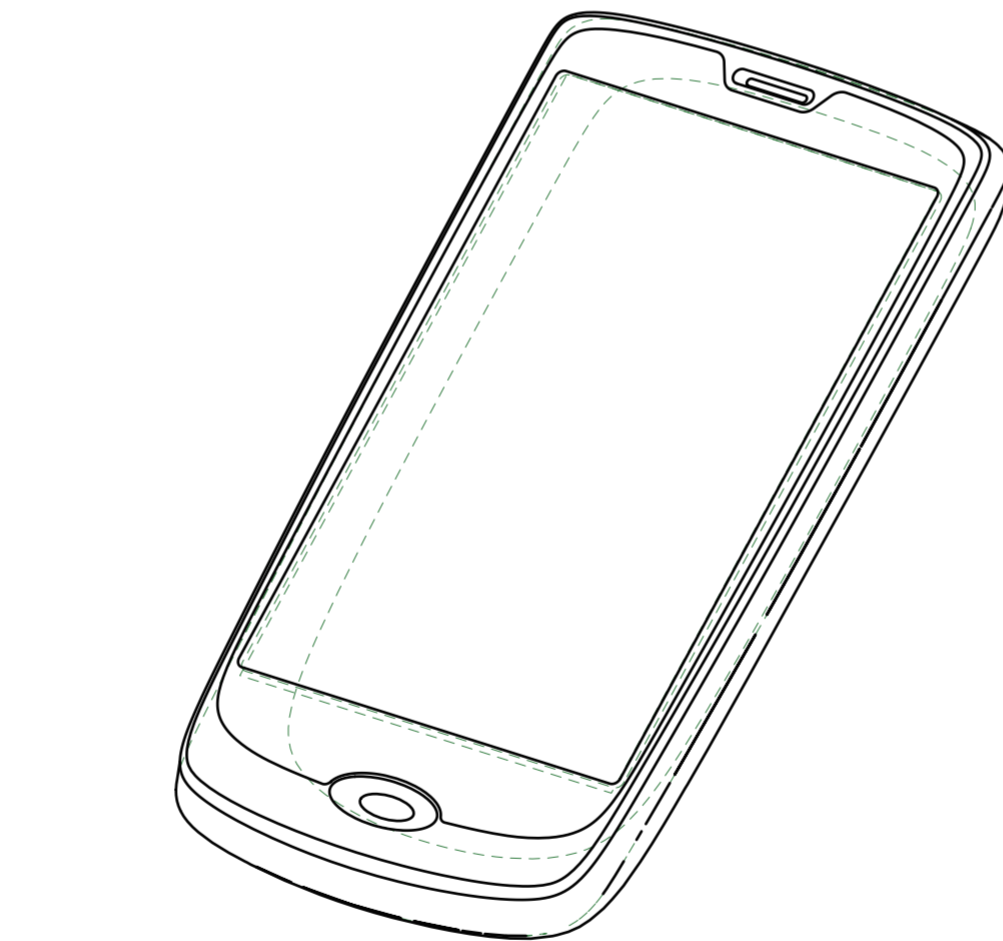
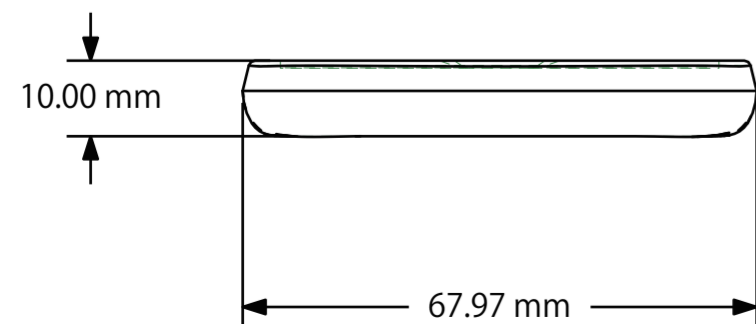
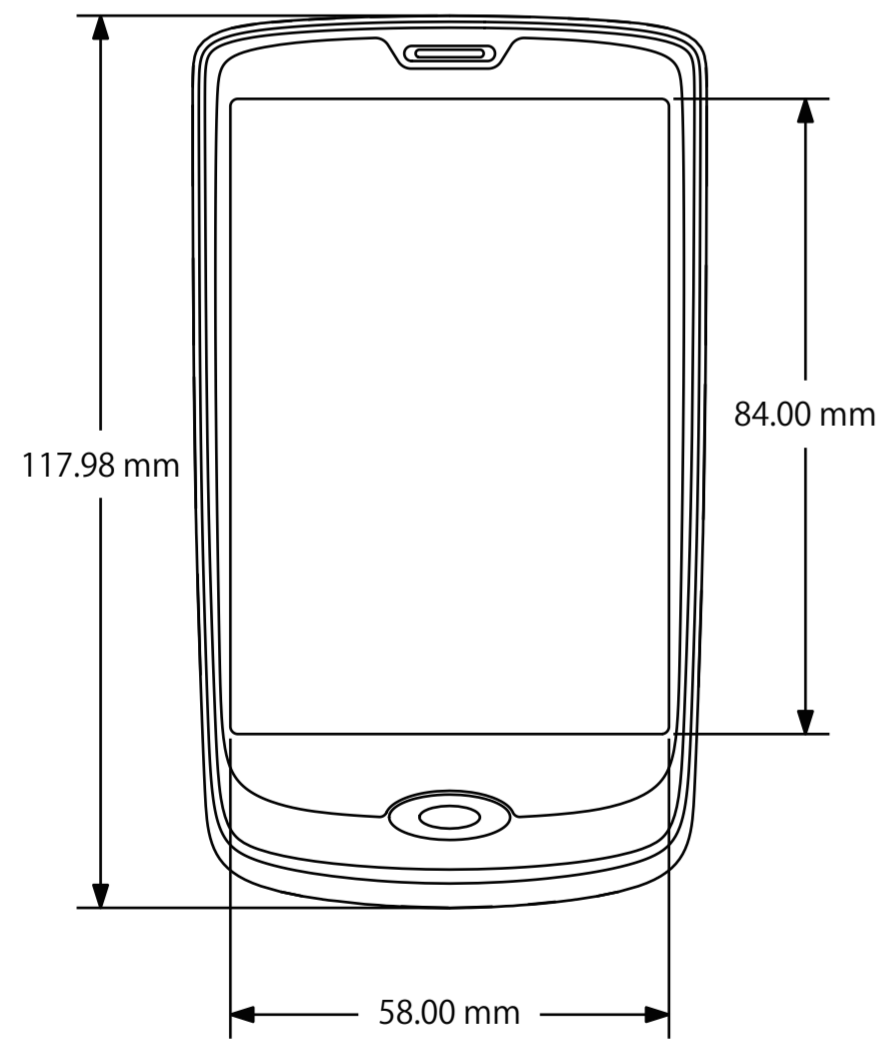

Normal Drawing

---